

# SYNAGOGUE DIVINELY DESIGNED IN WOOD.

A FULL VIEW OF THE SANCTUARY illustrates how the beautiful architectural woodwork creates a unique, sacred space.

Congregation Emanu-El B'ne Jeshurun in Fox Point, Wisconsin, has undergone a profound transformation from its beginnings in 1856, becoming a more diversified religious institution than its founders had ever envisioned. Gathering first in homes for worship, the community grew to include three tiny congregations until 1856 when they joined together to form B'ne Jeshurun.

A year later they moved into their first synagogue and 13 years later, 35 families established a new Congregation Emanu-El, and B'ne Jeshurun remained at its original building. Both groups flourished separately for 58 years until Emanu-El, in need of larger facilities, broke ground in 1922 for a new building. When plans for a new courthouse called for the demolition of B'ne Jeshurun's synagogue, the wheels were set in motion for the 1927 merger of the two Reform congregations -- Emanu-El B'ne Jeshurun.

In June 2008 the congregation broke ground for a renovation and expansion of its building.



Phillip Katz Project Development LLC of Mequon, Wisconsin, was selected as the architect for the project. Lange Bothers Woodwork Company, an AWI member firm from Milwaukee, was brought on board to fabricate the woodwork for this sacred space. After six years in the planning and 16 months of construction, the

new building opened September 11, 2009.

**BUILDING ENHANCEMENTS**

A new, beautiful and spacious sanctuary seats 318 people for regular worship services and programs. The sanctuary design by Phillip Katz is enhanced by a movable bima, a state of the art

▼ THE UNIQUELY DESIGNED PULPIT is custom fabricated of Maple.

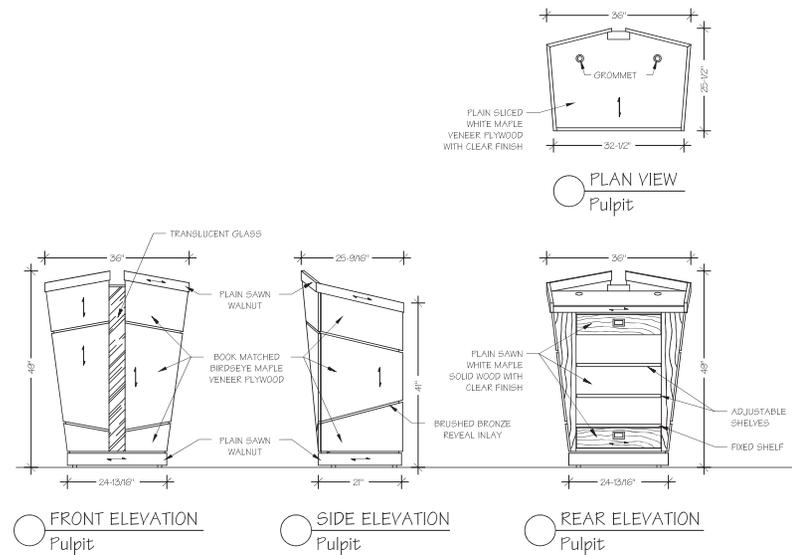

sound system, and artwork by internationally known Judaic artist, Tobi Kahn. The new sanctuary and community hall is able to accommodate a total capacity of 840 people including a mezzanine level over the rear of the sanctuary which has a seating capacity of 140 and an expansion area at the rear with 130 seats.

As a single room, the new community hall can seat 250 people auditorium style. The design of the community hall also includes enclosed, built-in bookcases to house the congregation's library collection, making it accessible to all. The community hall enables the congregation to hold catered events and

receptions, accommodating more than 250 people at tables with a dance floor.



An all new fully functioning catering kitchen supports table or buffet service and allows for on-site cooking for moderate sized social events, school events and other programs. The new building provides a variety of prefunction and small function spaces, including a lounge, the corridor outside of the sanctuary and community hall, and the entry coming into the building. Additionally, the facility includes a "green" HVAC ice storage system to more efficiently control and regulate interior temperature, operable windows, a "green roof" and

◀ A CLOSE-UP OF THE PULPIT shows the figured Maple with Walnut accents.

many natural materials.

Eleven refurbished classrooms and office space for the religious school is included, along with administrative offices, patios, gardens, memorial wall, gift shop, security, rest rooms, landscaping, and computer and telecommunication systems. New museum quality display cases allow the congregation's extensive collection of Judaica to be displayed.

**WOODWORK FEATURES**

An array of wood species and beautiful custom fabricated architectural woodwork adorn the new building. Elements produced by Lange Bros. Woodwork include wall paneling, pulpit, reading table, scroll holder, sanctuary benches and moveable platform, kitchen cabinets, display cases, fireplace mantle, reception desk, interior street benches, acoustical slat wall panels and camera enclosure.



The \$10 million project features Maple, Walnut, Acacia, Walnut Burl, Douglas Fir and laminate countertops. "Wood brings warmth to the space and is consistent with a refined organic aesthetic," explains Katz. "The design is timeless influenced by historic precedent and poetic Biblical narrative. We have truly created a unique Jewish expression of sacred space."

The moveable doors and acoustical slat wall panels were the most challenging aspect of the project, says woodworker Randy Lange. "We researched the hardware to find proper action per specified requirements on the demountable walls. We provided mock-ups to show the look and feel of the products we were providing. Also, we discussed wood movement issues and other potential problems."

A collaborative and respectful working relationship among the woodworking firm, designer and general contractor resulted in a beautiful, sacrosanct space for the entire congregation to appreciate. 🕍

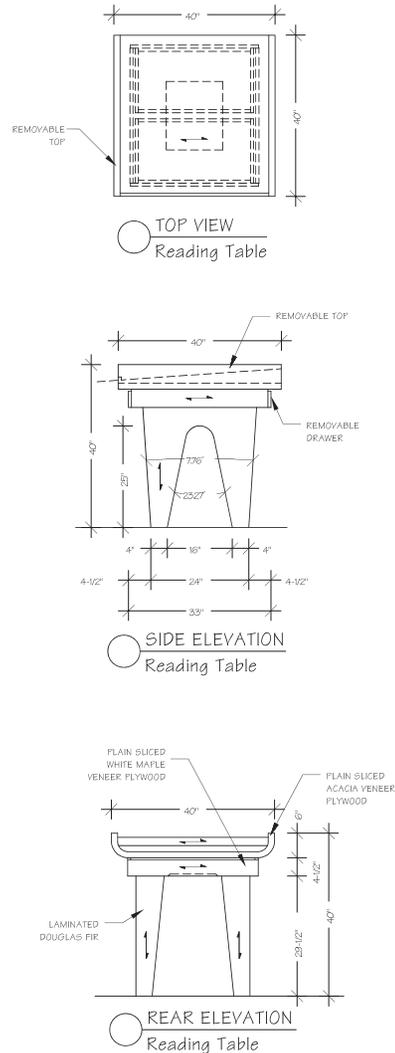

Project:	Emanu-El B'ne Jeshurun Synagogue	Fox Point, WI
Project Owner:	Congregation Emanu-El B'ne Jeshurun	Fox Point, WI
Woodworker:	Lange Bros. Woodwork Co., Inc.	Milwaukee, WI
Architect:	Phillip Katz Project Development LLC	Mequon, WI
General Contractor:	Northtrack Construction	Fox Point, WI
Photographer:	Phillip Katz	Mequon, WI